

# Compact hydraulic power packs type KA

for short-term and intermittent service



Operating pressure  $p_{\max}$  = 700 bar  
Flow  $Q_{\max}$  = 19.9 l/min

Additional information:  
Compact hydraulic power packs type HC D 7900  
type HCG D 7900 G  
type HK D 7600 ++

## 1. Design and general information

The compact hydraulic power pack type KA serves to supply pressurized fluid for intermittently or short-term operated hydraulic circuits.

The basic hydraulic power pack consists:

- the tank (available in different sizes)
- the drive motor (available for different voltages and power requirements)
- the radial piston or gear pump directly driven by the motor shaft

The compact style obtained with this design represents an essential advantage opposite conventional units. Complete turn-key solutions can be easily arranged via a wide range of connection blocks (see D 6905++) and directly mountable valve banks (see photo).

There is a wide field of applications for these compact power packs within tool machines, jig assemblies and general mechanical engineering.



### Order example

KA 24 ST/H 0,66  
- A 2/650  
- VB 11 FM-H 3 N-1-N 24-  
3x400 V 50 Hz

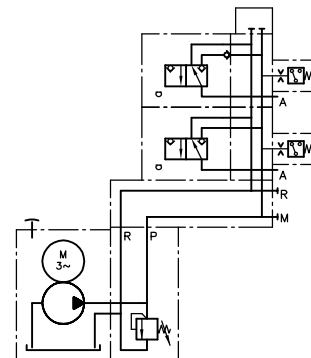

## 2. Available versions, type coding

Order examples:

**KA 24 1 S KS E/H1,81 - A 1/280 - 3x400V 50 Hz**

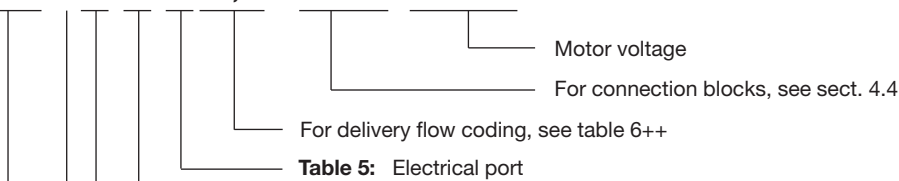

**Table 5:** Electrical port

Coding	Note
-	Standard (Terminal box)
P	Plug Co. HARTING
E, PE	Electrical connection with additional interference suppression in the terminal box or at the plug Co. HARTING. For alternatives, see sect. 3.3, page 7

**Table 4:** Options

Coding	Note	vertically	horizontal
no coding	without optional equipments	●	●
K	Fluid level gauge	●	●
KS	Fluid level gauge with float switch (NO-contact)	●	-
S	Float switch (NO-contact)	-	●
D	Float switch (NC-contact)	-	●
T	Temperature switch	●	●

**Table 3:** Installed position

Coding	Note
S	Vertical version
L	Horizontal version

**Attention:**

- A version for horizontal use can be used for vertical operation.
- A version for vertical use equipped with a radial piston pump (coding H...) can not be operated in horizontal position

**Table 2:** Tank size

Coding		Filling volume $V_{fill}$	Usable filling volume $V_{use}$
--	Standard	4.0 l	2.0 l
1	Extension 1	5.0 l	3.0 l
2	Extension 2	8.0 l	6.0 l

**Table 1:** Basic type and drive power

Coding	Nominal power (kW)	Nominal speed 50 Hz ( $min^{-1}$ )
KA 21	0.55	2790
KA 22	1.1	2790
KA 23	0.37	1360
KA 24	0.75	1360
KA 28 1)	1.0	1370

1) Only available together with extension 1 or 2

Order examples: KA 24 S KST / H 0,66 - A 4 F 1/700 - 3x400 V 50 Hz

Table 6: Version with radial piston pump and 3-phase motor

Basic type	Characteristic data	Delivery flow coding, geom. displacement, perm. pressure, delivery flows					
		Piston diameter (mm)					
		4	5	6	7	8	9
	Delivery flow coding (3 cyl.)	<b>0,33</b>	<b>0,47</b>	<b>0,66</b>	<b>0,91</b>	<b>1,18</b>	<b>1,51</b>
	Geom. displacement $V_g$ (cm <sup>3</sup> /rev.)	0.23	0.35	0.51	0.69	0.91	1.15
KA 21	Pressure $p_{max}$ (bar)	700	465	320	235	180	140
	Delivery flow 50 Hz	0.57	0.89	1.28	1.75	2.28	2.89
	$Q_{Pu}$ (lpm) 60 Hz	0.69	1.08	1.56	2.12	2.77	3.50
KA 22	Pressure $p_{max}$ (bar)	700	700	700	700	570	450
	Delivery flow 50 Hz	0.57	0.89	1.28	1.75	2.28	2.89
	$Q_{Pu}$ (lpm) 60 Hz	0.69	1.08	1.56	2.12	2.77	3.50
KA 23	Pressure $p_{max}$ (bar)	700	620	430	315	240	190
	Delivery flow 50 Hz	0.30	0.46	0.66	0.90	1.18	1.49
	$Q_{Pu}$ (lpm) 60 Hz	0.36	0.56	0.80	1.09	1.43	1.80
KA 24	Pressure $p_{max}$ (bar)	700	700	700	700	650	510
	Delivery flow 50 Hz	0.30	0.46	0.66	0.90	1.18	1.49
	$Q_{Pu}$ (lpm) 60 Hz	0.36	0.56	0.80	1.09	1.43	1.80
KA 28	Pressure $p_{max}$ (bar)	700	700	700	700	700	590
	Delivery flow 50 Hz	0.30	0.46	0.66	0.90	1.18	1.49
	$Q_{Pu}$ (lpm) 60 Hz	0.36	0.56	0.80	1.09	1.43	1.80

Basic type	Characteristic data	Delivery flow coding, geom. displacement, perm. pressure, delivery flows					
		Piston diameter (mm)					
		4	5	6	7	8	9
	Delivery flow coding (6 cyl.)	<b>0,59</b>	<b>0,93</b>	<b>1,33</b>	<b>1,81</b>	<b>2,36</b>	<b>2,99</b>
	Geom. displacement $V_g$ (cm <sup>3</sup> /rev.)	0.45	0.71	1.02	1.39	1.81	2.29
KA 21	Pressure $p_{max}$ (bar)	360	230	160	115	90	70
	Delivery flow 50 Hz	1.14	1.78	2.57	3.49	4.56	5.77
	$Q_{Pu}$ (lpm) 60 Hz	1.38	2.16	3.11	4.24	5.54	7.01
KA 22	Pressure $p_{max}$ (bar)	700	700	510	370	285	225
	Delivery flow 50 Hz	1.14	1.78	2.57	3.49	4.56	5.77
	$Q_{Pu}$ (lpm) 60 Hz	1.38	2.16	3.11	4.24	5.54	7.01
KA 23	Pressure $p_{max}$ (bar)	485	310	215	155	120	95
	Delivery flow 50 Hz	0.59	0.92	1.33	1.81	2.36	2.99
	$Q_{Pu}$ (lpm) 60 Hz	0.71	1.11	1.60	2.18	2.85	3.61
KA 24	Pressure $p_{max}$ (bar)	700	700	580	425	325	255
	Delivery flow 50 Hz	0.59	0.92	1.33	1.81	2.36	2.99
	$Q_{Pu}$ (lpm) 60 Hz	0.71	1.11	1.60	2.18	2.85	3.61
KA 28	Pressure $p_{max}$ (bar)	700	700	670	490	375	295
	Delivery flow 50 Hz	0.59	0.92	1.33	1.81	2.36	2.9
	$Q_{Pu}$ (lpm) 60 Hz	0.71	1.11	1.60	2.18	2.85	3.61

**Order examples:** KA 28 L KDT / **Z 6,9** - AS 1 F 2/100 - 3x400 V 50 Hz

**Table 7:** Version with gear pump

Basic type	Characteristic data		Delivery flow coding, geom. displacement, perm. pressure, delivery flows					
			<b>Z 1,1</b>	<b>Z 1,7</b>	<b>Z 2,0</b>	<b>Z 2,7</b>	<b>Z 3,5</b>	<b>Z 4,5</b>
	Delivery flow coding							
	Geom. displacement $V_g$	( $\text{cm}^3/\text{rev.}$ )	0.8	1.1	1.4	1.9	2.4	3.1
<b>KA 21</b>	Pressure $p_{\max}$	(bar)	170	135	105	75	60	45
	Delivery flow	50 Hz	2.0	2.7	3.5	4.7	6.0	7.8
	$Q_{Pu}$ (lpm)	60 Hz	2.4	3.3	4.2	5.8	7.3	9.4
<b>KA 22</b>	Pressure $p_{\max}$	(bar)	170	170	170	170	170	150
	Delivery flow	50 Hz	2.0	2.7	3.5	4.7	6.0	7.8
	$Q_{Pu}$ (lpm)	60 Hz	2.4	3.3	4.2	5.8	7.3	9.4
<b>KA 23</b>	Pressure $p_{\max}$	(bar)	170	170	140	100	80	60
	Delivery flow	50 Hz	1.0	1.4	1.8	2.4	3.1	4.0
	$Q_{Pu}$ (lpm)	60 Hz	1.2	1.7	2.2	2.9	3.7	4.8
<b>KA 24</b>	Pressure $p_{\max}$	(bar)	170	170	170	170	170	170
	Delivery flow	50 Hz	1.0	1.4	1.8	2.4	3.1	4.0
	$Q_{Pu}$ (lpm)	60 Hz	1.2	1.7	2.2	2.9	3.7	4.8
<b>KA 28</b>	Pressure $p_{\max}$	(bar)	170	170	170	170	170	170
	Delivery flow	50 Hz	1.0	1.4	1.8	2.4	3.1	4.0
	$Q_{Pu}$ (lpm)	60 Hz	1.2	1.7	2.2	2.9	3.7	4.8

Basic type	Characteristic data		Delivery flow coding, geom. displacement, perm. pressure, delivery flows					
			<b>Z 5,2</b>	<b>Z 6,4</b>	<b>Z 6,9</b>	<b>Z 8,8</b>	<b>Z 9,8</b>	<b>Z 11,3</b>
	Delivery flow coding							
	Geom. displacement $V_g$	( $\text{cm}^3/\text{rev.}$ )	3.6	4.4	4.8	6.1	7.0	7.9
<b>KA 22</b>	Pressure $p_{\max}$	(bar)	130	105	95	75	65	55
	Delivery flow	50 Hz	9.0	11.0	12.1	15.3	17.6	19.9
	$Q_{Pu}$ (lpm)	60 Hz	11.0	13.4	14.6	18.6	21.4	24.1
<b>KA 24</b>	Pressure $p_{\max}$	(bar)	145	120	110	85	75	65
	Delivery flow	50 Hz	4.7	5.7	6.2	7.9	9.1	10.3
	$Q_{Pu}$ (lpm)	60 Hz	5.6	6.9	7.5	9.6	11.0	12.4
<b>KA 28</b>	Pressure $p_{\max}$	(bar)	170	140	125	100	85	75
	Delivery flow	50 Hz	4.7	5.7	6.2	7.9	9.1	10.3
	$Q_{Pu}$ (lpm)	60 Hz	5.6	6.9	7.5	9.6	11.0	12.4

### 3. Additional parameters

#### 3.1 General

Nomenclature	Constant delivery pump			
Design	Valve controlled, 3- and 6-cylinder radial piston pump or gear pump			
Direction of rotation	Radial piston pump - any Gear pump - counterclockwise (Direction of rotation can only be detected by checking the delivery flow - the connection of 2 of the 3 leads have to be changed at 3-phase versions, when there is no flow)			
Installed position	Vertically (KA...S) or horizontally (KA...L)			
Mounting	Tapped holed M8, see dimensional drawings			
Mass (weight) (without fluid)		3 cyl.	6 cyl.	Gear pump
	KA 21	10.9	11.5	12.7
	KA 22	13.2	13.6	13.4
	KA 23	11.2	11.6	13.0
	KA 24	13.0	13.4	13.2
	KA 28	14.7	15.1	12.9
	Extension 1	+0.7 kg		
	Extension 2	+2.2 kg		
Hydraulic connection	via directly mounted connection blocks, see table in sect. 5.6 Basic pump: For connection hole pattern, see sect. 4			

For Mass (weight) of the required connection blocks, see the respective pamphlets (listing in sect. 5.6)

#### 3.2 Hydraulic

Pressure	Pressure side (port P): Depending on flow, see sect. 2 Suction side (tank ): Ambient air pressure. Not suited for charging.			
Starting against pressure	The 3-phase versions may start against pressure $p_{max}$ .			
Hydraulic fluid	Hydraulic oil acc. to DIN 51524 table 1 to 3, 10 ... 68 mm <sup>2</sup> /s at 40°C (ISO VG 10 to 68 conf. DIN 51 519) Optimal operation range: approx. 10...500 mm <sup>2</sup> /s Viscosity range: min. approx. 4; max. approx. 800 mm <sup>2</sup> /s Also suitable are biologically degradable pressure fluids type HEPG (Polyalkylenglycole) and HEES (synth. ester) at operation temperatures up to approx. +70°C.			
Temperature	Ambient: approx. -40...+80°C; Fluid: -25...+80°C; Pay attention to the viscosity range! Start temperature down to -40°C are allowable (Pay attention to the viscosity range during start!), as long as the operation temperature during subsequent running is at least 20K higher. Biological degradable pressure fluids: Pay attention to manufacturer's information. With regard to the compatibility with sealing materials do not exceed +70°C.			
Filling and usable volume	Tank size			
	Coding	Filling volume $V_{fill}$	Usable filling volume $V_{use}$	
	--	Standard	4.0 l	2.0 l
	1	Extension 1	5.0 l	3.0 l
	2	Extension 2	8.0 l	6.0 l

#### 3.3 Electrical

The following data apply to radial piston and to gear pumps The drive motor is part of the pump and can not be removed, see description in sect. 1.

Connection	Versions with plug Co. HARTING: cable 1.5 mm <sup>2</sup> Versions with integrated terminal box: Blade type plugs 6.3 Co. AMP Cable gland M 20x1,5 (not scope of delivery)
Protection class	IP 54 conf. DIN EN 60529 / IEC 60529, applies to the complete power pack reference protection class when compared with pure electrical device (means of production)
Safety class	DIN VDE 0100 safety class 1
Insulation	Lay-out conf. DIN VDE 0110 <ul style="list-style-type: none"> <li>• up to 500 VAC nom. phase voltage (wire - wire) for 4- or 3-wire AC-mains L1-L2-L3-PE (3-phase mains) <b>with</b> earthed star connection point.</li> <li>• up to 300 VAC nom. phase voltage (wire - wire) for 4- or 3-wire AC-mains L1-L2-L3 (3-phase mains) <b>without</b> earthed star connection point.</li> </ul>



**Notes to ensure EMC (electromagnetic compatibility)**

Non permissible spikes are emitted (EN 60034-1 Abs. 19) when hydraulic power packs (inductive motor acc. to EN 60034-1 sect. 12.1.2.1) are connected to a system (e.g. power supply acc. to EN 60034-1 sect. 6). Tests regarding the conformity with EN 60034-1 sect. 12.1.2.1 and/or VDE 0530-1 are not required. Electro-magnetic fields may be generated during switching the motor On/Off. This effect can be minimized by means of a filter e.g. type 23140, 3 • 400V AC 4 kW 50-60 Hz (Co. Murr-Elektronik, D-71570 Oppenweiler).

An optional interference suppression can be integrated in the terminal box or at the plug Co. HARTING (see table 5)

**$I_M - p_B$  - operation curve**

These hydraulic power packs are intended for intermittent service S3. It is therefore possible to load the motor above its nominal performance rating for short periods. This will cause the power consumption to rise on 140 to 160 % of  $I_N$  during max. operation pressure ( $p_B = p_{max}$ ).

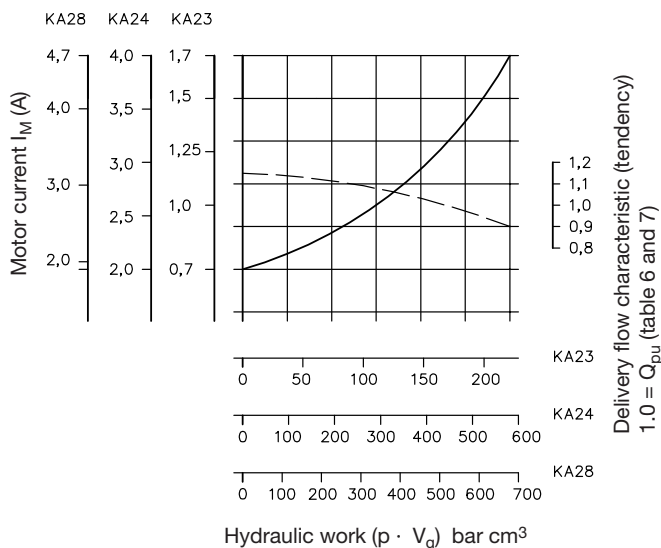
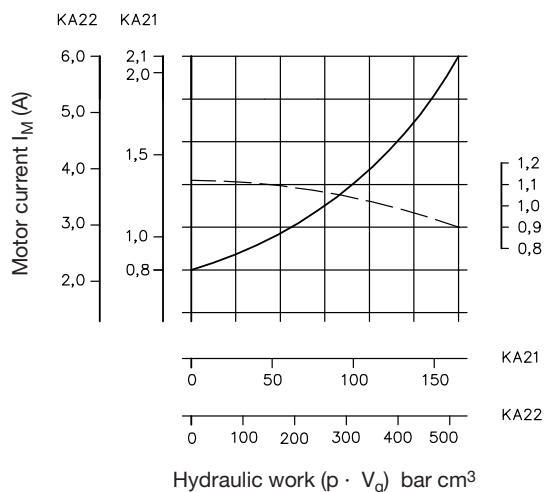

### 3.4 Built-up of heat

The persistent service temperature to expect for the HC compact hydraulic power pack depends largely on the local operating conditions. A simple coherence valid for all operating conditions does not exist. The following determination of the most likely expected inertia excess temperature or the permissible relative duty cycle is only a rough guide line and does only apply to circuits without any further throttling devices (cycle steps including starting against pressure limiting valves, pressure control valves or throttling valves). A test for evaluating the persistent service temperature should be undertaken under the in-tended load conditions and duty cycles (monitoring the oil temperature), if such throttle devices are utilized and / or the load period is above 30 % per cycle. The persistent service temperature to be expected can be determined by multiplying the excess temperature  $\Delta\vartheta_B$  with a factor representing the throttling losses when these can be roughly evaluated in percent (see curve at the bottom of this page).

A recalculation of the expected persistent service temperature is often super-fluous as the relative duty cycles are blow 10...15% ED in most applications. This also applies if the averaged pressure figure  $p_{aver}$  is extremely low due to prolonged periods of stand-still.

$$\vartheta_{fluidB} \approx \Delta\vartheta_B + \vartheta_U$$

$$\%ED = \frac{t_B}{t_B + t_A} \cdot 100$$

- $\vartheta_{fluidB}$  (°C) = Persistent service temperature of the oil filling (max. approx. 80°C)
- $\Delta\vartheta_B$  (K) = Inertia excess temperature depending on load, see rough calculation
- $\vartheta_U$  (°C) = Ambient temperature in the surrounding area of the compact hydraulic power pack
- $p_{aver}$  (bar) = Calculated average pressure per duty cycle  $T = t_B + t_A$  (representing the load conditions only)
- $t_B$  (s) = Load period per cycle
- $t_A$  (s) = Period of standstill per cycle
- $t_{1,2,3...}$  (s) = Periods for pressure  $p_{1,2,3...}$  within the load period  $t_B$
- $p_{1,2,3...}$  (bar) = Pressure during periods  $t_{1,2,3...}$  within the load period  $t_B$
- % ED (-) = Relative load period per cycle

$$p_{12} = \frac{p_1 + p_2}{2}$$

$$p_m = \frac{1}{T} (p_1 t_1 + p_2 t_2 + p_3 t_3 + \dots)$$

$$\%ED = \frac{t_1 + t_2 + t_3 + \dots}{T} \cdot 100$$

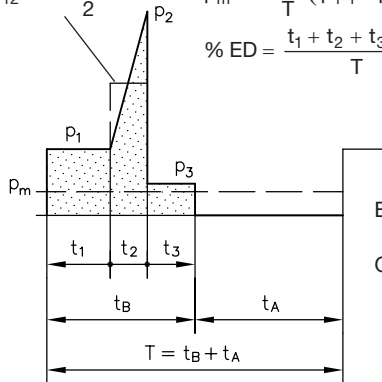

Example : KA 24 S / H 1,81  
 ( $p_{max} = 490$  bar)  
 Given  $p_1 = 80$  bar  $t_1 = 5$ s  
 $p_{12} = 80 \rightarrow 350$  bar  $t_2 = 2$ s  
 $p_3 = 40$  bar  $t_3 = 3$ s  
 Cycle period  $T = 30$ s  
 $V_g = 1,39$  cm<sup>3</sup>/rev.

Found  $p_m = \frac{1}{30} \left( 80 \cdot 5 + \frac{80 + 350}{2} \cdot 2 + 40 \cdot 3 \right) \approx 31$  bar (only calculated)

$(p_m \cdot V_g) = 1,39 \cdot 31 \approx 43$  bar cm<sup>3</sup>

$\%ED = \frac{5 + 2 + 3}{30} \cdot 100 = 33\%$

KA 23, KA 24, KA 28

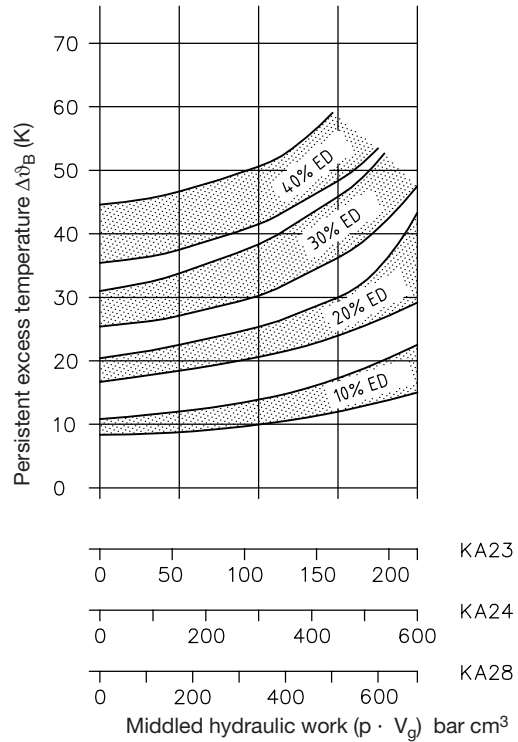

KA 21, KA 22

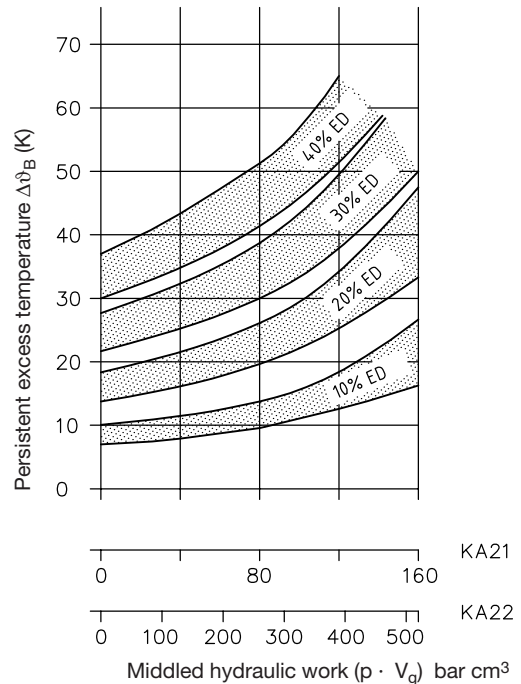

Above curve shows a persistent excess temperature in the range of  $\Delta\vartheta_B \approx 30 \dots 35$  K. A persistent service temperature of the oil filling  $\vartheta_{fluidB} \approx (30 \dots 35) + 25 \approx 55 \dots 60$ °C will result from an ambient temperature of 25°C.

### 3.5 Running noise

The indicated ranges of the noise level are determined under realistic conditions (with corresponding spreads). Compact hydraulic power pack with lower delivery flows tend as a rule to the lower, those with higher deliveries to the upper limit. The ranges change fluently into each other.

The running noise may be increased by local, unfavorable installation conditions. Mounting the hydraulic power pack on resonance capable machinery covers or in the corners of rooms where noise is directed back should be avoided.

The compact hydraulic power pack should be mounted on "silent blocks" or other damping devices to prevent or minimize the conduction of body sound onto other sound radiating machinery parts. Pipes to the consumers should be connected via short hoses to the hydraulic power unit. The silent blocks should be only opposed to lateral loads, if possible. Further details may be found in the technical information of the manufacturer of these silent blocks.

Conditions during the tests: Workshop, ambient sound level approx. 42 dB(A)  
 Point of measurement 1m above the floor  
 Distance to the unit 1m  
 Pump standing on sound deadening material, thickness 50 mm

Measuring instrument: Precision sound level meter, conforming DIN IEC 651 class 1

#### Radial piston pump

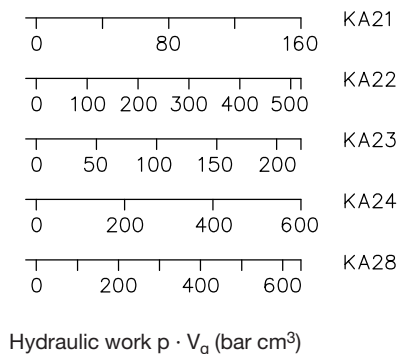
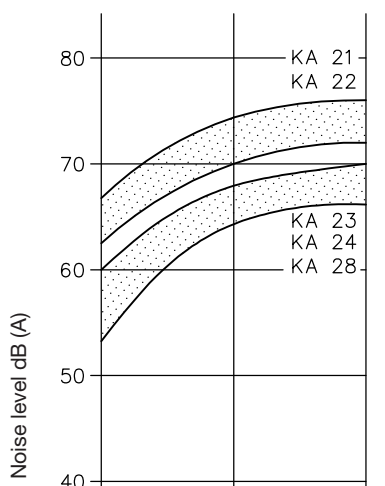

#### Gear pump

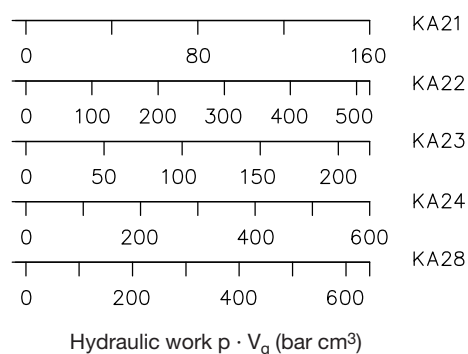
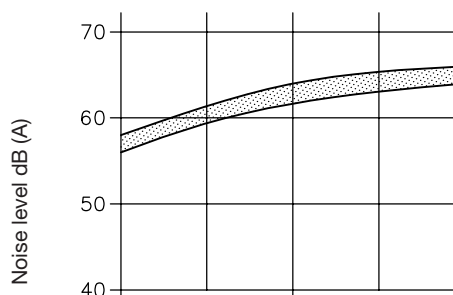

### 3.6 Run-down

A certain pressure rise will occur due to pump motor run-down, if the pump is directly connected to a hydraulic cylinder via a pipe, such as e.g. in the typical connection pattern for clamping equipment (connection block B...) and if the power unit is switched off by a pressure switch as soon as a pre-selected pressure is achieved. The extent of this additional pressure rise depends on the pre-selected pressure, the volume of the connected consumers and the pump delivery rate. If such pressure rises are undesired, it will be necessary to reset the pressure limiting valve to match the shut-off point of the pressure switch. The result will be that all excess delivery of the pump during run-down will be conducted to the tank via the pressure limiting valve.

Procedure for matching is as follows:

1. Fully open the pressure limiting valve.
2. Adjusting the pressure switch on highest value (turning the adjustment screw clockwise up to the stop).
3. Start the pump (pressure gauge and all consumers connected) and turn up the pressure limiting valve until the pressure gauge shows the desired final operation pressure.
4. Turn back the pressure switch until the pump is switched off at the preset pressure (see step 3)
5. Lock pressure switch and pressure limiting valve in position.

The effect of excessive run-down pressure may also be minimized by utilizing an accumulator or providing additional volume in the consumer line. If the compact hydraulic power pack is running under full load, i.e. the preset pressure is close to the maximum permissible pressure as listed in sect. 2.1 and 2.2, then effectively no run-down will occur, as the pump will stop almost immediately after shut-off.

## 4. Dimensions

All dimensions in mm, subject to change without notice!

### 4.1 Vertical version

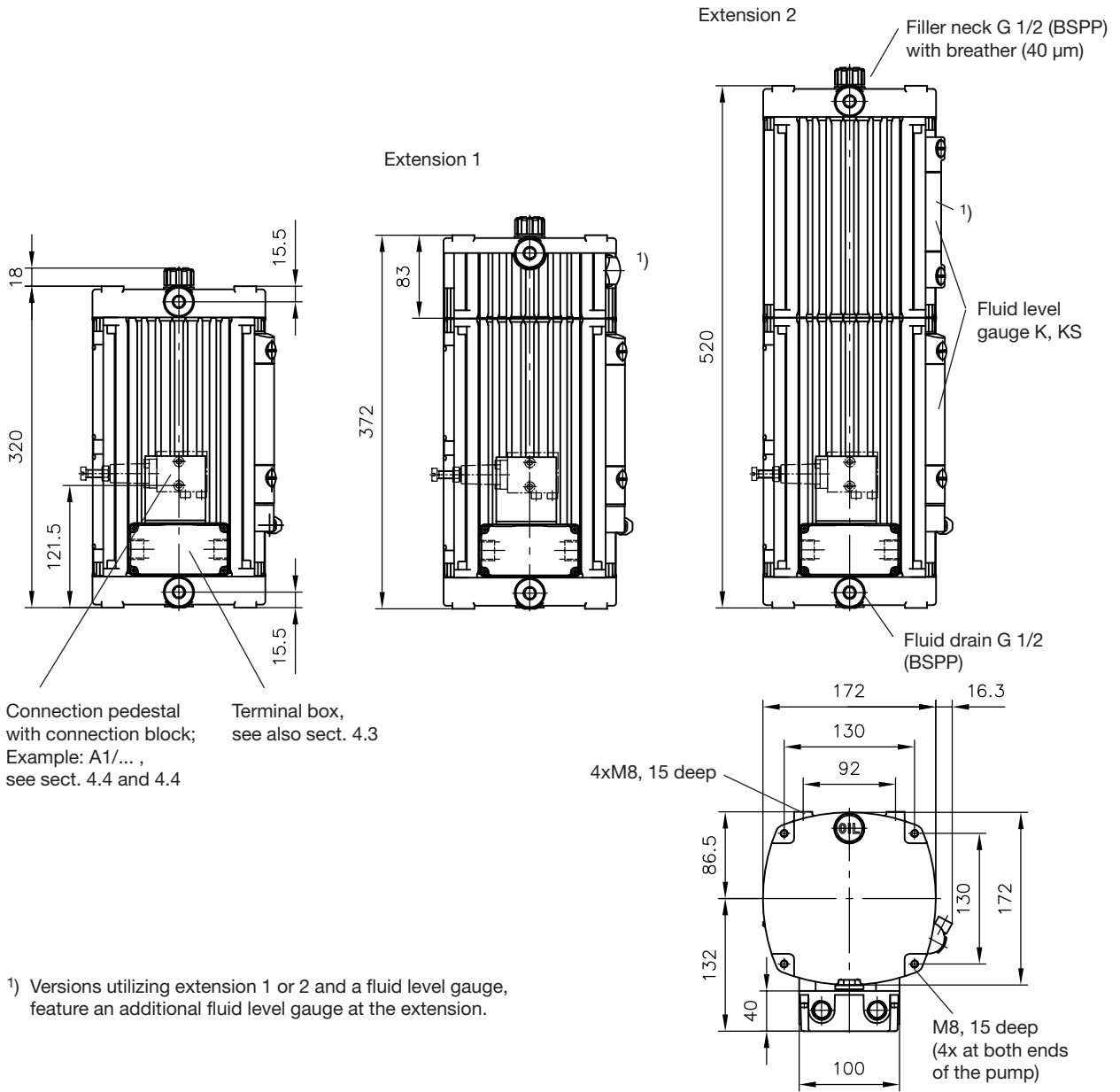

### 4.2 Horizontal version

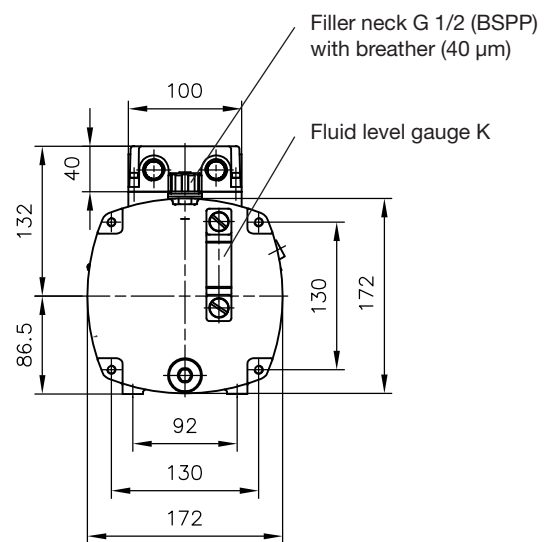
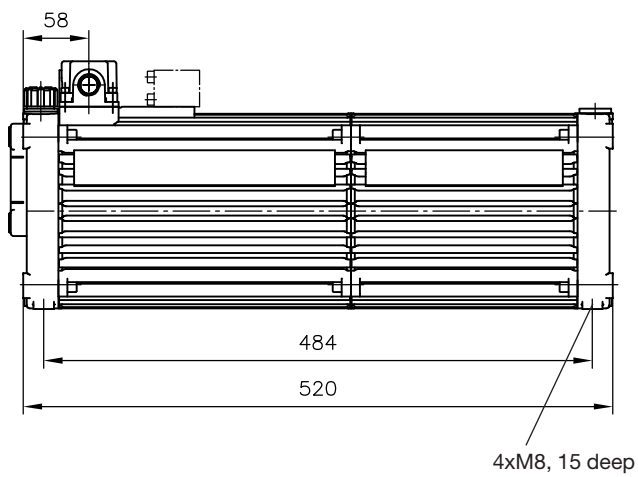
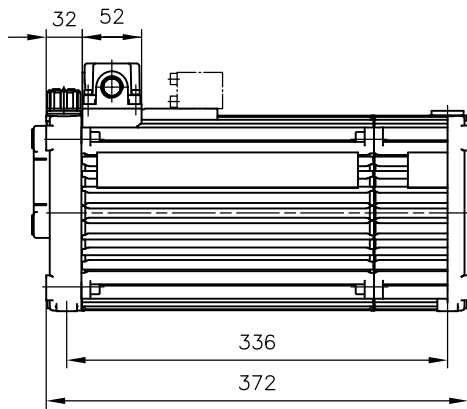
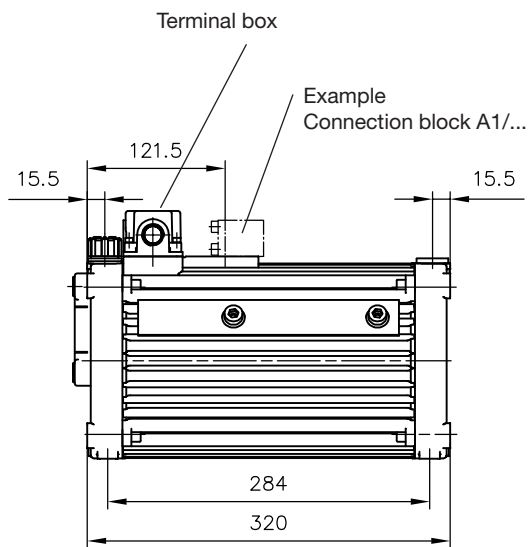

### 4.3 Electrical and hydraulic connections

#### Hydraulic

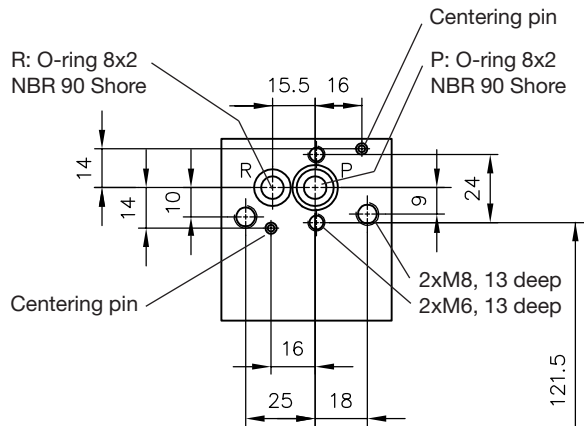

#### Electrical

#### Terminal box

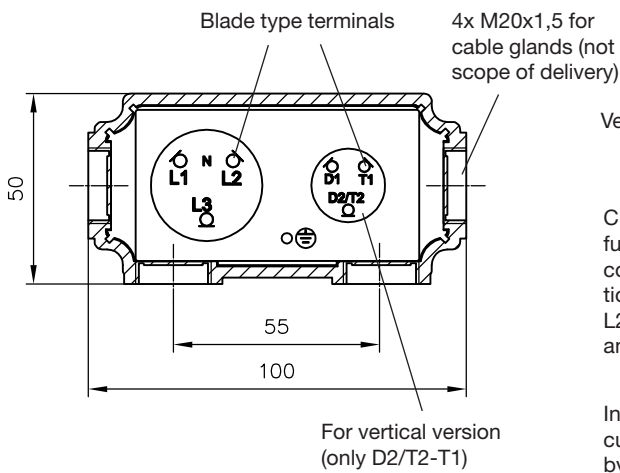

#### Version for 3-phase mains

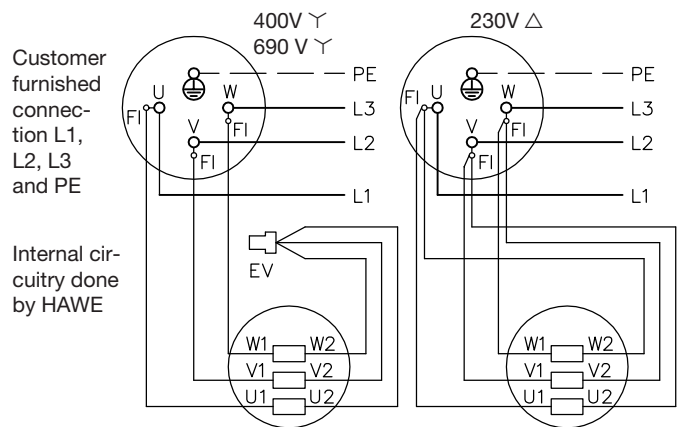

#### Plug Co. HARTING

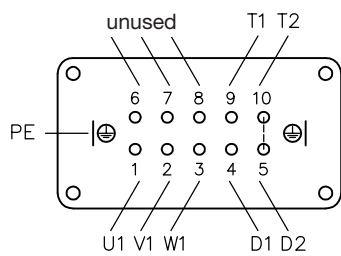

#### Float switch (vertical version) Coding **KS**



Plug  
DIN 43650-C  
(8 mm)



#### Temperature switch

Coding **T**  
(Plug Co. HARTING)

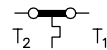

Coding **T**  
(terminal box)

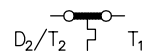

Float switch (horizontal version)  
Coding **S, D**

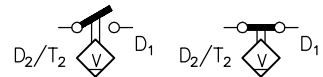

Coding **ST**  
(terminal box)

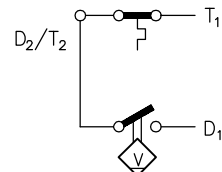

Coding **DT**  
(terminal box)

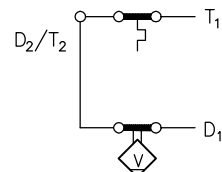

#### 4.4 Connection blocks (Overview)

The hydraulic power packs can be delivered together with connection blocks as well as with additional directional valves to form a hydraulic power pack unit which is completely assembled for immediate use (see example on page 1). For technical data, dimensions and further examples refer to the specified pamphlets.

Pamphlet	Coding	Port threads DIN ISO 228/1 (BSPP)	Pressure range from...to (bar) <sup>1)</sup>	Flow (lpm)	Integrated funct. elements <sup>12)</sup>			Brief notes concerny the connection block	Suitable directional valve banks for direct mounting <sup>1)</sup>
					Pressure limiting valve	Idle circula- tion valve	Return filter		
D 6905 C	<b>C5</b> <b>C6</b>	G 1/4 G 3/8	700 700	12 28	no no	no no	no no	Simple connection block	No possibility for mounting
D 6905 B	<b>B../...-...</b>	G 1/4 to G 1/2	450 (700)	8 ... 25	yes	no	no	For single acting lifting or clamping devices <sup>1) 2)</sup>	
D 6905 A/1	<b>A1../.. to</b> <b>A4../..</b>	G 1/4	(0) ... 700 in steps	12	yes	no	no	Most frequently used connection block with pressure limiting valve	①a ①b
	<b>A13../.. to</b> <b>A43../..</b>	G 3/8		18	yes	no	no		②
	<b>A51../.. and</b> <b>A61../..</b>	G 3/8		18	yes	no	no		③
	<b>AS(V)1../..</b> to <b>AS(V)4../..</b>	G 1/4	(0) ... 450 in steps	18	yes	yes	no	With idle circulation valves acc. to D 7490/1	①a ①b
	<b>AL11(12)../..</b>	G 1/4	51 ... 350 in steps	12	yes <sup>4)</sup>	yes <sup>4)</sup>	no	Automatic idle circu- lation <sup>4)</sup> (accumula- tor charging valve)	①a <sup>8)</sup>
	<b>A..F../..</b> <b>AS..F../..</b> <b>AM..F../..</b> <b>AK..F../..</b> <b>AL21F../..</b> <b>A...D../..</b>	G 1/4 to G 1/2 dep. on type and connection side	(0) ... 700 in steps depend- ing on type	15 ... 33 depend. on filler size	yes <sup>5)</sup>	yes <sup>6)</sup>	yes <sup>7)</sup>	With return filters 12 µm nom. 50%/30 µm abs. or pressure resistant 10 µm (β <sub>10</sub> = 75) with AL..D../.. and idle circu- lation valves, see <sup>6)</sup>	④ <sup>8)</sup>
	<b>AP1../.. and</b> <b>AP3../..</b>	G 1/4	5 ... 700	20	yes	yes <sup>9)</sup>	no	Proportional pressure limiting valve	①a ①b
D 6905 TÜV	<b>AX, ASX,</b> <b>APX</b>	G 1/4	80 ... 450	6 ... 10	yes	no	no	Pressure limiting valve with unit approval	
D 7230	<b>SKC11../..</b> to <b>SKC14../..</b>	G 1/4 and G 3/8	200...400 <sup>10)</sup>	12 ... 20	yes	yes <sup>11)</sup>	no	Integrated directional spool valve	
D 7450	<b>SWC1</b>	G 1/4	315	12	yes	yes <sup>11)</sup>	no	Integrated directional spool valve	Add-on spool valves D 7450

1) It should be kept in mind that the directional valve banks which can be directly mounted may have a max. permissible pressure below 700 bar.

2) Should be used for intermittent service only

3) The valves are directing radially to the outside

4) Hydraulic cut-off function acts as pressure limitation also

5) Depending on type also with additional proportional pressure limiting valve

6) Idle circulation valve acc. to D 7490/1 with AS..., acc. to D 7470 A/1 with AK... and AM..., with automatic idle circulation (accumulator charging valve) with AL21...

7) With pressure resistant filter at AL...D../..

8) Directional spool valve banks type SWR... are not ideally suited for mounting onto blocks type AL11(12) or AL21..., as the their always apparent leakage would provoke permanent activation. This effect could be minimized by using an accumulator.

9) May be used as idle circulation valve if the prop. solenoid is deenergized (approx. 5 bar)

10) Depending on actuation and flow pattern

11) For directional spool valves with internal connection P→R in idle position

12) Pressure limiting valves acc. to D 7000 E/1, 2/2-way directional valves acc. to D 7490/1, optional with additional check valve acc. to D 7445

①a BWN(H)1F... acc. to D 7470 B/1  
BWH2F... acc. to D 7470 B/1  
BVZP1F... acc. to D 7785 B

①b VB01(11)F... acc. to D 7302  
SWR(P)1F... acc. to D 7450  
SWR2F... acc. to D 7451  
SWS2F... acc. to D 7951

② BWH3F... acc. to D 7470 B/1

③ VB11G... and  
VB21G... acc. to D 7302

④ BWN(H)1F... acc. to D 7470 B/1  
BWH2F... acc. to D 7470 B/1  
BVZP1F... acc. to D 7785 B  
VB01(11)F... acc. to D 7302  
SWR(P)1F... acc. to D 7450 <sup>8)</sup>  
SWR2F... acc. to D 7451 <sup>8)</sup>  
SWS2F... acc. to D 7951 <sup>8)</sup>