

Prop. directional spool valve type PSL and PSV

The directional spool valve bank type PSL is designed for constant delivery pump systems (pressure/flow controller) whereas the type PSV is for variable displacement pump systems. Both are available in three sizes. They serve to control the direction of motion and provide infinite control of the speed of motion of hydraulic consumers regardless of their load. Several consumers may be operated simultaneously and independently of each other.

The main field of application is mobile hydraulics (e.g. crane controls etc.). These valve banks can be tailored to a specific application, requiring unequal max. consumer flows at port A and B as well as additional functions such as functional cut-off.

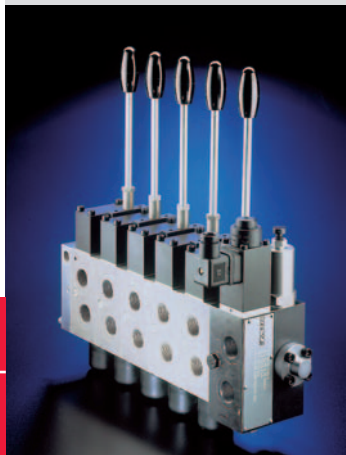

Nomenclature: Prop. directional spool valve acc. to the Load-Sensing principle

Design: Valve bank or Manifold mounting (also as valve bank)

Actuation: Manual
 • Return spring
 • Detent
 Electro-hydraulic Pressure
 • Hydraulic
 • Pneumatic

P_{max}: 400 ... 420 bar

Q_{max. consumer}: 3 ... 210 lpm

Q_{pu max}: approx. 250 lpm

Basic types and general parameters

Basic type and size	Flow (lpm)		Oper. pressure p _{max} (bar)	Tapped ports (BSPP)	
	Q _{consumerp}	Q _{pu max}		P and R	A and B
PSL ... - 2	3 ... 54	80	420	G 1/2	G 3/8
PSV ... - 2	3 ... 54	80	420	G 1/2	G 3/8
PSL ... - 3	3 ... 120	200	420	G 1/2, G 3/4, G 1	G 1/2, G 3/4
PSV ... - 3	3 ... 120	200	420	G 1/2, G 3/4, G 1	G 1/2, G 3/4
PSL ... - 5	16 ... 210	250	400	G 1, G 1 1/4	G 1
PSV ... - 5	16 ... 210	250	400	G 1, G 1 1/4	G 1

Additional versions

- PSLF.. valve bank, sub-plate mounted (size 3 and 5)
- Versions available with UNF-ports (valve banks) or SAE-flange (manifold mounting version)

Valve bank coding

PSL 41/380 - 3 - 32 H 63/40 A280 B 350 /EA

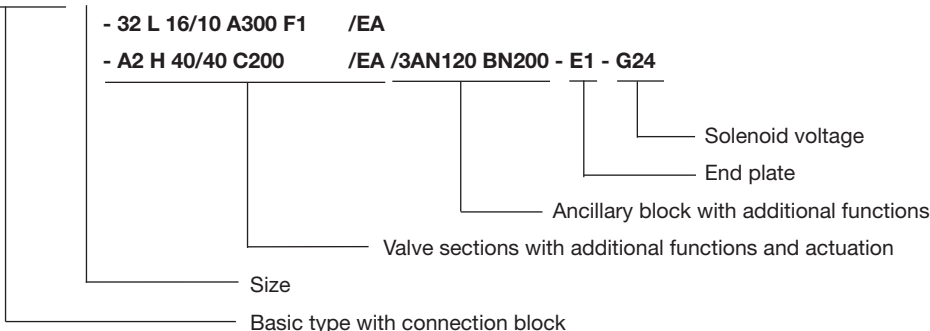

Connection blocks

Basic type

Brief description

Symbol

PSL Connection block for constant delivery pump systems with incorporated 3-way flow controller and pressure limiting valve

PSV Connection block for variable displacement pump systems with pressure limiting valve

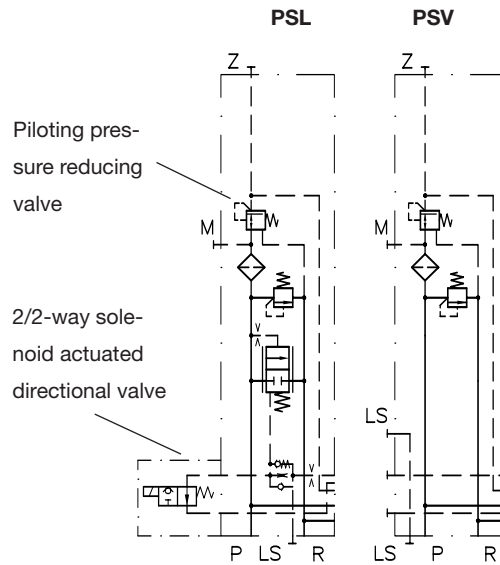

Additional versions (connection blocks)

- Integrated piloting pressure reducing valve, feeding the electro-hydraulic actuation
- 2/2-way solenoid actuated directional valve for arbitrary idle pump circulation
- Additional damping of the 3-way flow controller or pump controller
- Additional idle circulation valve minimizing the circulation back pressure
- Version without pressure limiting valve (type PSV)
- Version available where the pump gallery can be blocked arbitrarily

Symbol

max. 12 valve may be combined in a valve bank

Basic symbol L M F H J B R O P A Q K T N

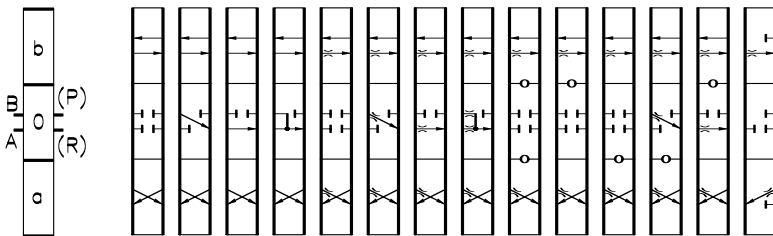

P, A, Q, K, and T with positive overlapping
 P, A, Q, K, T not for size 2 and 5
 N not for size 2 and 5

- 1) Functional cut-off
- 2) Secondary pressure limiting valves (optional for consumer port A and/or B)

Coding for max. consumer flow

Size 2	3	6	10	16	25	40			
Size 3	3	6	10	16	25	40	63	80	
Size 5				16	25	40	63	80	120 160

- Coding represents the max. flow (lpm) at consumer ports A or B for version with inflow controller
- Flow for A or B may be selected individually
- It is possible to achieve 60 lpm (size 2), 120 lpm (size 3) and 240 lpm (size 5) for consumer ports A or B by raising the control pressure.

Additional functions in the valve sections

Additional functions in the ancillary block

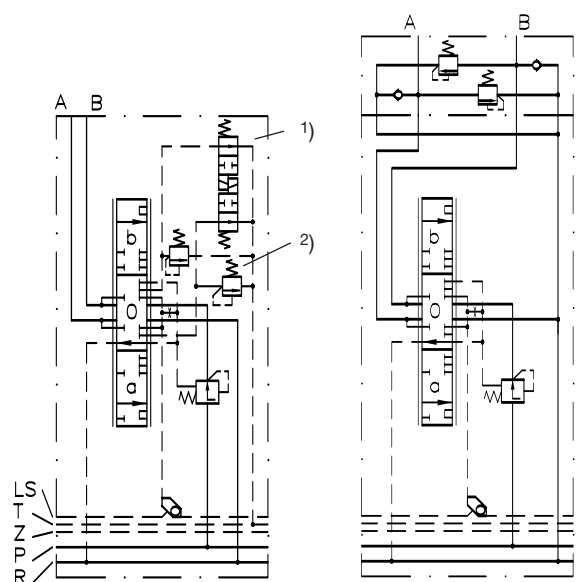

Additional versions (valve sections)

- Load pressure signal pick-up with A, B; joint for A and B
- 3/3-directional spool valve with 2-way inflow and outflow controller
- Version without 2-way inflow controller
- Prop. pressure limitation for individual functions
- Additional ancillary blocks for various other functions

Actuations

Basic type	Brief description
A	Manual actuation
C	Detent (stepless)
E	Electro-hydraulic actuation
EA	in combination with manual actuation
H, P	Hydraulic and pneumatic actuation
HA, PA	in combination with manual actuation
HEA	Combination of actuation H, E, and A

Symbol (example)



For combination of electro-hydraulic and manual actuation

Solenoid voltage 12V DC, 24V DC
also available versions conforming ATEX

Intermediate plates

- Electrically or hydraulically actuated shut-off valve for all subsequent consumers
- With pressure limiting valve limiting the operation pressure for all subsequent valves

- Arbitrary flow reduction for all subsequent consumers
- Priority module, size 3

End plates

Basic type	Brief description	Symbol
E 1	End plate (serie)	E 1 E 2
E 2	With additional Y-port for LS-input signal	

Additional versions (end plates)

- End plate with internal drain line (without T-port)
- End plates with additional P- and R-port
- Adapterplate enabling combination of size 5 with size 3 (coding ZPL 53), size 5 with size 2 (coding ZPL 52) and size 3 with size 2 (coding ZPL 32)

Example

PSL 41/350 - 3 - 32 J 25/16 A300 F1 /EA
 -42 O 80/63 C250 /EA
 -42 J 63/63 A100 B120 F3 /EA
 -31 L 40/16 /A - E2 - G24

Valve bank type PSL for constant delivery pumps

Connection block:

- Coding for port size (4, G 3/4 (BSPP))
- Coding for piloting pressure reducing valve (1)
- Coding for set pressure at pressure limiting valve (350 bar)

Size:

- Coding (-3-)

1. Valve section: (as an example for all additional sections)

- Valve section with coding for port size consumer (here 3, G 1/2 (BSPP))

- Coding for the kind of the valve section (here 2)
- Flow pattern (here J)
- Coding for max. flow rate at consumer port A and B (here 25 and 16 lpm)
- Coding for additional functions (here A 300; secondary-pressure limiting valve at port A factory set to 300 bar, shut-off function for port A (here F1))
- Coding for the actuation (here EA)

End plate:

- Coding for end plate (here E 2)
- Coding for solenoid voltage 24V DC (here G24)

Symbol (example)

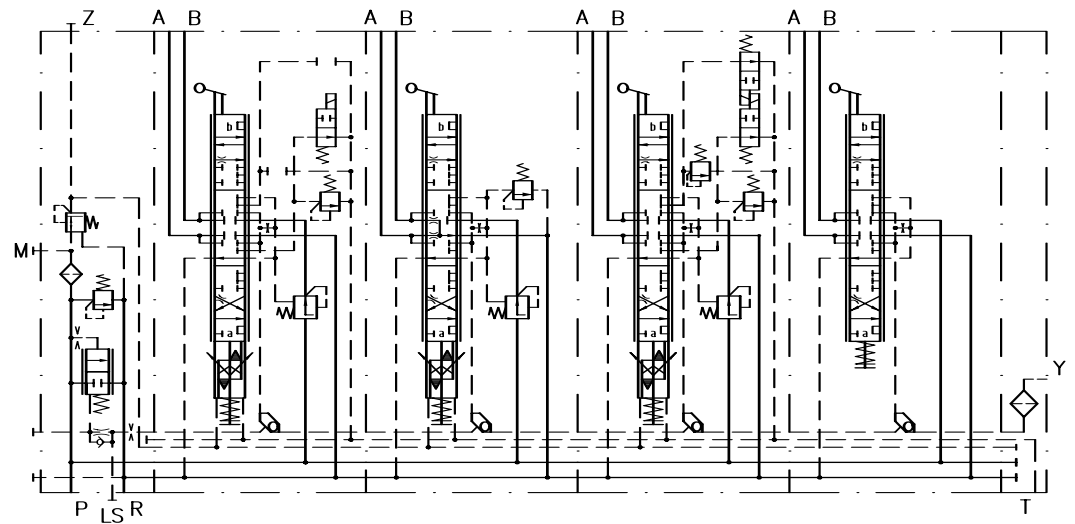

Dimensions

(see order example)

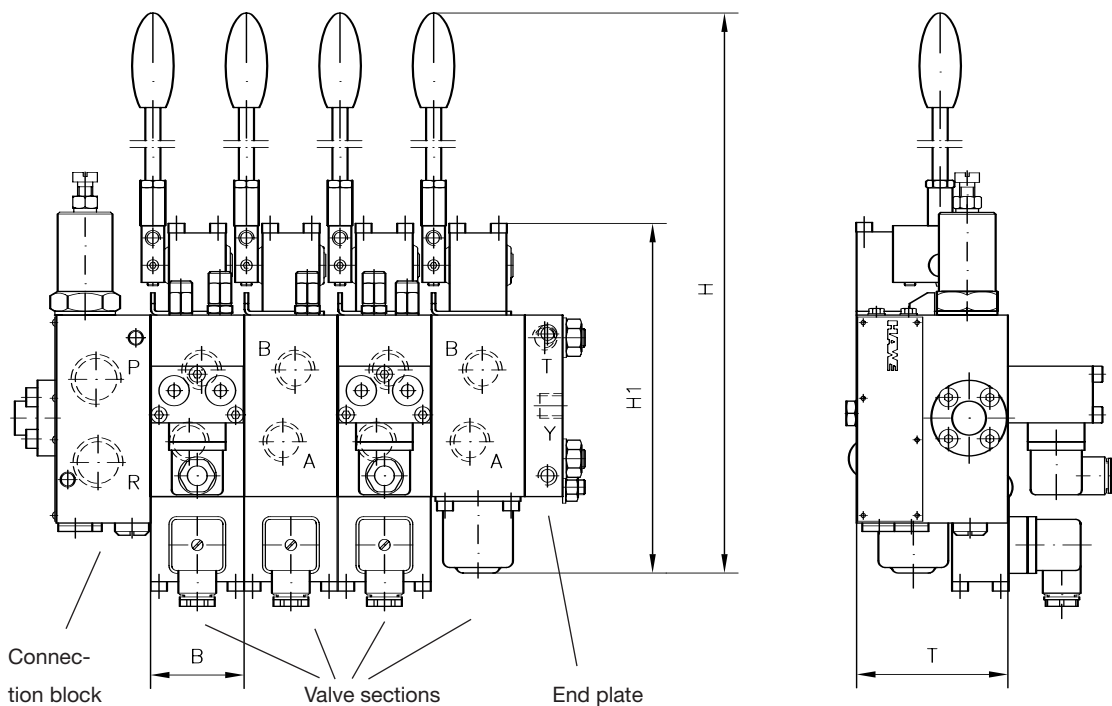

All dimensions in mm, subject to change without notice!

Basic type	H	H1	B	T	m (kg) per valve section ³⁾
PSL ..-2-	approx. 272	approx. 150	40	60	1.8 ... 2.9
PSV ..-2-	approx. 272	approx. 150	40	60	1.8 ... 2.9
PSL ..-3-	approx. 364	approx. 195	50	80	3.3 ... 4.1
PSV ..-3-	approx. 364	approx. 195	50	80	3.3 ... 4.1
PSL ..-5-	approx. 400	approx. 224	62.5	100	3.7 ... 4.5
PSV ..-5-	approx. 400	approx. 224	62.5	100	3.7 ... 4.5

³⁾ Dep. on actuation and additional functions

Additional informations

- Prop. directional spool valve type PSL/PSV size 2 D 7700-2
- type PSL/PSV size 3 D 7700-3
- type PSL/PSV size 5 D 7700-5
- type PSLF/PSVF size 3, 5 D 7700-F
- Over-center valves type LHT, LHDV D 7918, D 7770
- Joystick type EJ D 7844
- Prop. amplifier (modul) type EV1M2 D 7831/1
- Prop. amplifier (board design) type EV 22K2 D 7817/1
- Programmable logic valve control type PLVC D 7845 ++
- See also section "Devices for special applications"
(Hydraulic for mobile applications, Devices for explosion hazardous areas, conforming ATEX; Prop. valves)

For page and section of the devices additionally listed, see type index